

Technische fiche :

MC 30-2 ST5



	Technical characteristics		Metrisch	Imperiaal
1.1	Manufacturer		Manitou	Manitou
1.2	Model Name		MC 30-2 ST5	MC 30-2 ST5
1.3	Power source		Diesel	Diesel
1.4	Operator type		Seated	Seated
1.5	Max. capacity	Q	3000 kg	6614 lbs
1.6	Load centre of gravity	c	500 mm	19.685 in
1.8	Load distance, centre of drive axle to fork	x	626 mm	24.646 in
1.9	Wheelbase	y	1900 mm	74.803 in
	Weight			
2.1	Service weight		4368 kg	9630 lbs
2.2	Weight on front axle (laden) / rear axle (laden)		6432 kg / 936 kg	14180 lbs / 2064 lbs
2.3	Weight on front axle (Unladen) / rear axle (Unladen)		1654 kg / 2714 kg	3646 lbs / 5983 lbs
	Wheels			
3.1	Tyres type		Pneumatic	Pneumatic
3.2	Dimensions of front wheels		12,5/80-18/12 SL R4	12,5/80-18/12 SL R4
3.3	Dimensions of rear wheels		7,00-12/12 ED PLUS	7,00-12/12 ED PLUS
3.5	Number of front wheels / rear wheels		2 / 2	2 / 2
3.5.2	Number of drive wheels		2	2
3.6	Front wheel gauge	b10	1159 mm	45.63 in
3.7	Rear wheel gauge	b11	1176 mm	46.299 in
	Dimensions			
4.1	Tilt of Mast Forward (deg) / Backward (deg)	α / β	12 / 10	12 / 10
4.7	Height of overhead guard (cabin) / Overall height of low overhead guard (Buggie version)	h6 / h6*	2155 mm / 1990 mm	84.843 in / 78.346 in
4.8	Seat height/stand height	h7	1034 mm	40.709 in
4.19	Overall length	l1	4265 mm	167.913 in
4.20	Length to face of forks	l2	3085 mm	121.457 in
4.21	Overall width	b1	1450 mm	57.087 in
4.22	Forks section x width x length	s / e / l	45 mm x 100 mm / 1200 mm	1.772 in x 3.937 in / 47.244 in
4.23	Fork carriage ISO 2328 (class/form) A/B		FEM 3A	FEM 3A
4.24	Fork carriage width	b3	1260 mm	49.606 in
4.31	Ground clearance below mast	m1	300 mm	11.811 in
4.32	Ground clearance at centre of wheelbase	m2	310 mm	12.205 in
4.33	Aisle width for 1000 x 1200 pallet widthways	Ast	4626 mm	182.126 in
4.35	Turning radius	Wa	2650 mm	104.331 in
	Performances			
5.1	Travel speed (laden / unladen)		12 km/h / 24.5 km/h	7.5 mph / 15.2 mph
5.2	Lifting speed (laden / unladen)		0.47 m/s / 0.46 m/s	1.54 ft/s / 1.51 ft/s
5.3	Lowering speed (laden / unladen)		0.5 m/s / 0.3 m/s	1.64 ft/s / 0.98 ft/s
5.5	Drawbar pull (Laden)		1680 daN	1680 daN
5.7	Gradeability (laden)		23 %	23 %
5.10	Service brake		Hydraulic brakes by loss of pressure	Hydraulic brakes by loss of pressure
	Engine			
7.1	Engine brand / model / norm		Kubota / D1803 CRT E5B / Stage V	Kubota / D1803 CRT E5B / Stage V
7.2	Engine power according to ISO 1585		37 kW	37 kW
7.3	Rated speed		2700 rpm	2700 rpm
7.4	Number of cylinders / Capacity of cylinders		3 - 1826 cm ³	3 - 111.43 in ³
7.5	Fuel consumption according to VDI cycle		5.3 l/h	5.3 l/h
	Miscellaneous			
8.1	Type of drive control		Electronic	Electronic
8.2	Working hydraulic pressure for attachments		230 Bar	16 PSI
8.3	Oil flow rate for attachments		43 l/min	43 l/min
8.4	Sound level at the driver's ear according to DIN 12 053		75 dB(A)	75 dB(A)

Tekening met afmetingen

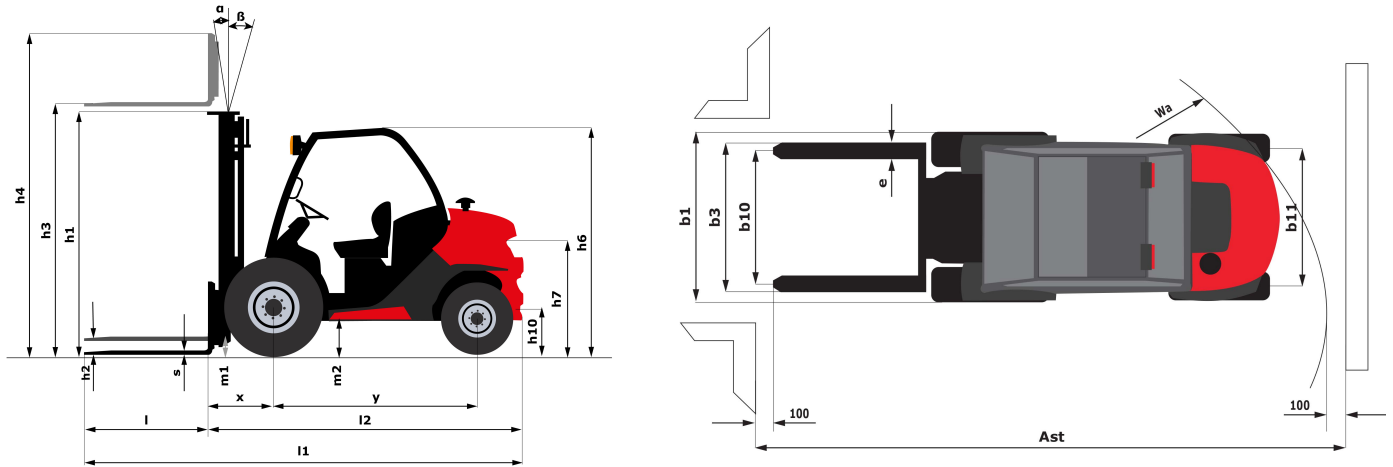

Kenmerken van de masten en restcapaciteiten

Full Visibility Duplex		FVD 33	FVD 37	FVD 45
h1 - Height mast lowered *	mm	2338	2598	3038
h2 - Free lift	mm	117	117	117
h3 - Lifting Height	mm	3300	3700	4500
h4 - Height mast extended *	mm	4090	4490	5290
α / β - Mast inclination (front / rear)	°	12 / 10	12 / 10	12 / 10

Free Lift Triplex		FLT 34	FLT 37	FLT 40	FLT 43	FLT 47	FLT 55
h1 - Height mast lowered *	mm	1988	2088	2188	2338	2438	2788
h2 - Free lift	mm	1235	1335	1435	1585	1685	2035
h3 - Lifting Height	mm	3400	3700	4000	4300	4700	5500
h4 - Height mast extended *	mm	4236	4536	4836	5136	5536	6336
α / β - Mast inclination (front / rear)	°	12 / 10	12 / 10	12 / 10	12 / 10	12 / 10	6 / 6
Residual capacity with hooked-on side shift (Off road load chart)	kg	1800					
Height at max capacity	mm	2700					
Residual capacity without attachment (Off road load chart)	kg	1750					
Height at max capacity with hooked-on sideshift	mm	2700					

Full Visibility Triplex		FVT 33
h1 - Height mast lowered *	mm	1878
h2 - Free lift	mm	129
h3 - Lifting Height	mm	3300
h4 - Height mast extended *	mm	4079
α / β - Mast inclination (front / rear)	°	12 / 10

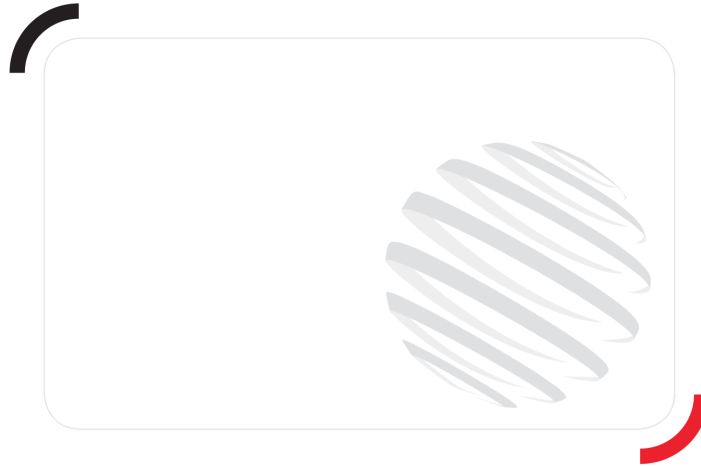

Siège Social
430 rue de l'Aubinière - 44150 Ancenis Cedex - France
Tel: +33(0)2 40 09 10 11 - Fax: +33 (0)2 40 09 10 97
www.manitou.com



Deze publicatie geeft een beschrijving van de versies en configuratiemogelijkheden van de Manitou-producten, waarvan de uitrusting kan verschillen. De afgebeelde uitrustingen in deze brochure kunnen standaard, optioneel of niet leverbaar zijn, afhankelijk van de versies. Manitou behoudt zich het recht voor om op te allen tijde en zonder voorafgaande kennisgeving de vermelde specificaties te wijzigen. De weergegeven specificaties zijn niet bindend voor de fabrikant. Voor meer bijzonderheden kunt u uw Manitou dealer raadplegen. Dit document is niet contractueel. De presentatie van de producten is niet contractueel. Specificatielijst is niet uitputtend. De logo's, evenals de visuele identiteit van de onderneming zijn eigendom van Manitou en mogen niet zonder toestemming worden gebruikt. Alle rechten voorbehouden. De foto's en schema's in deze brochure zijn bedoeld als informatie en zijn indicatief.

MANITOU BF NV - Naamloze vennootschap met raad van bestuur - Kapitaal: 39 668 399 euro - 857 802 508
RCS Nantes